

# 自动扶梯驱动主机

Escalator driving machine

## ET160-III

### 产品特点 Product Characteristics

产品自重: 400kg

噪音级别: <58dB (A)

扭转振动: <2.0mm/s

水平和垂直振动: <0.8~1.2mm/s

额定输出扭矩: 1072N·m~2925N·m

置式: 左置或右置 (此图为右置)

Deadweight: 400kg

Noise level: <58dB(A)

Torsional vibration: <2.0mm/s

Horizontal and vertical vibrations: <0.8~1.2mm/s

Rated output torque: 1072N·m~2925N·m

Arrangement: left side or right side (The picture is for right side)



### 外形和安装尺寸 Overall dimensions and mounting dimensions

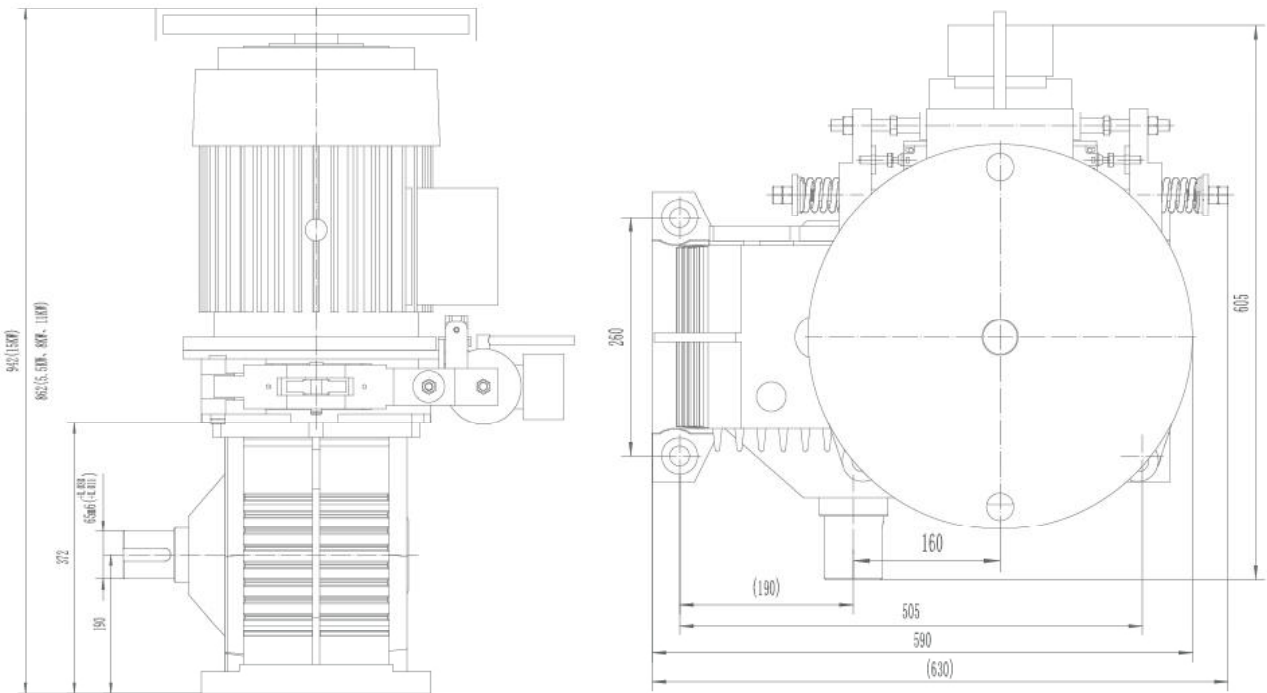

型号 Type	规格 Specification	输出扭矩 Output Torque (N·m)	速比 Reduction Ratio	电机型号 Type of Motor	功率 Power (kw)	电机转速 Motor Speed (r/min)	电源 Power Source (V/Hz)	电流 Current (A)	制动电压 Brake Voltage (V)
ET160-III	X	1072	2:49	FTMSIII-C160S-6	5.50	960	380/50	13.8	AC220
	XI	1560		FTMSIII-C160M-6	8.00			18.5	
	XII	2145		FTMSIII-C160L1-6	11.0			24.5	
	XIV	2925		FTMSIII-C160L2-6	15.0			32.5	