

自动扶梯驱动主机

Escalator driving machine

ETR112

产品特点 Product Characteristics

产品自重: 522kg

噪音级别: <58dB (A)

水平和扭转振动: <0.8-1.2mm/s

额定输出扭矩: 1376N·m~2580N·m

置式: 左置或右置 (此图为左置)

Deadweight: 522kg

Noise level: <58dB(A)

Horizontal and torsional vibration: <0.8~1.2mm/s

Rated output torque: 1376N·m~2580N·m

Arrangement: left side or right side (The picture is for left side)



外形和安装尺寸 Overall dimensions and mounting dimensions

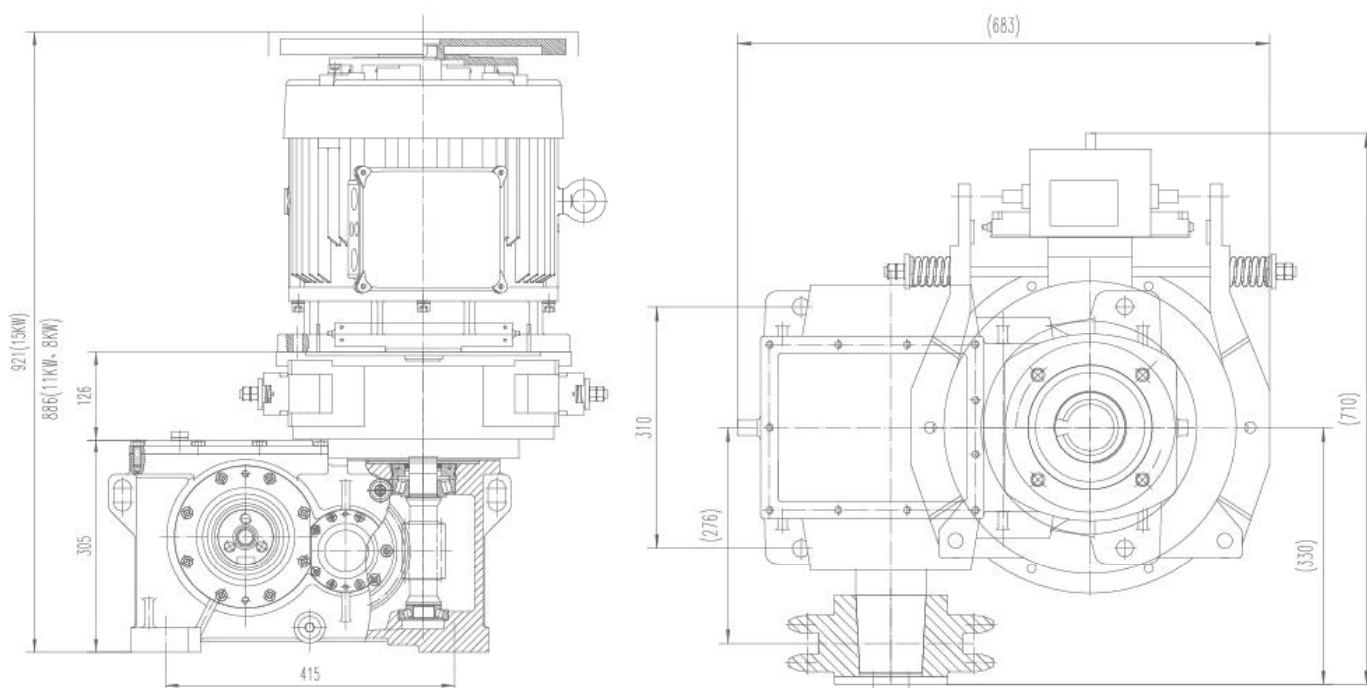

型号 Type	规格 Specification	输出扭矩 Output Torque (N·m)	减速比 Reduction Ratio	电机型号 Type of Motor	功率 Power (kw)	电机转速 Motor Speed (r/min)	电源 Power Source (V/Hz)	电流 Current (A)	制动电压 Brake Voltage (V)
ETR112	X	1376	18.99	FTMSIII-C160M-6D1	8.00	960	380/50	18.5	AC220
	XI	1892		FTMSIII-C160L1-6D1	11.0	960		24.5	
	XII	2580		FTMS-C200-6	15.0	975		32.5	