

有齿曳引机

Gear traction machine

YJ245

产品特点 Product Characteristics

曳引比: 1:1、2:1

额定载重: 1000、2000kg

额定梯速: 0.5、0.63、1.0m/s

最大提升高度: 60m

噪音级别: <65dB (A)

扭转振动: <3.0mm/s

水平和垂直振动: <0.8mm/s

制动器电压: 制动电压DC110V, 保持电压DC55V

置式: 只有左置



Traction ratio: 1:1、2:1

Rated capacity: 1000、2000kg

Rated elevator speed: 0.5、0.63、1.0m/s

Max. lifting height: 60m

Noise level: <65dB(A)

Torsional vibration: <3.0mm/s

Horizontal and vertical vibrations: <0.8mm/s

Brake voltage: DC110V for brake opening, and DC55V for brake holding

Arrangement: only left side

外形和安装尺寸 Overall dimensions and mounting dimensions

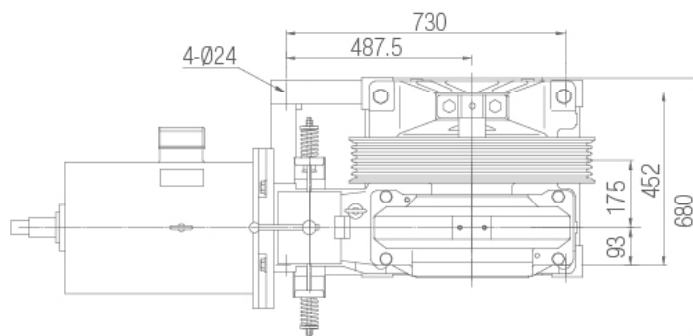
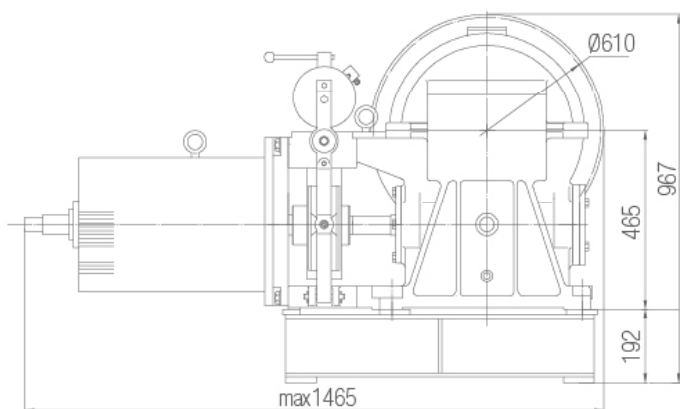

型号 Type	规格 Specification	曳引比 Traction Ratio	额定梯速 Rated Speed (m/s)	额定载重 Rated Load (kg)	静态载重 Static Capacity (kg)	速比 Reduction Ratio	曳引轮规格 Specification of Traction Sheave	槽距 Groove Spacing (mm)	电机型号 Type of Motor	功率 Power (kw)	电机转速 Motor Speed (r/min)	电源 Power Source (V/Hz)	电流 Current (A)	自重 Weight (kg)	推荐提升高度 Recommended lifting height [m]
YJ245	A-II	1:1	0.50	1000	6000	1:61	Ø610-5-13	20	YPTD160M2-6	7.5	967	380/50	15.8	598	60
	B-IV	1:1	1.00	1000		2:61			YPTD160L1-6	11	967	380/50	22.9		
	B-V	2:1	0.63	2000		2:61			YPTD160L1-4B1	13	1300	380/45	26.4		