

有齿曳引机

Geard traction machine

YJ245-B

产品特点 Product Characteristics

曳引比: 2:1

额定载重: 3000、3500kg

额定梯速: 0.5m/s

最大提升高度: 50m

噪音级别: < 65dB (A)

扭转振动: < 3.0mm/s

水平和垂直振动: < 0.8mm/s

制动器电压: 制动电压DC110V, 保持电压DC110V

置式: 左置或右置 (此图为右置)

Traction ratio: 2:1

Rated capacity: 3000、3500kg

Rated elevator speed: 0.5m/s

Max. lifting height: 50m

Noise level: < 65dB(A)

Torsional vibration: < 3.0mm/s

Horizontal and vertical vibrations: < 0.8mm/s

Brake voltage: DC 110V for brake opening,
and DC 110V for brake holding

Arrangement: left side or right side (The picture is for right side)



外形和安装尺寸 Overall dimensions and mounting dimensions

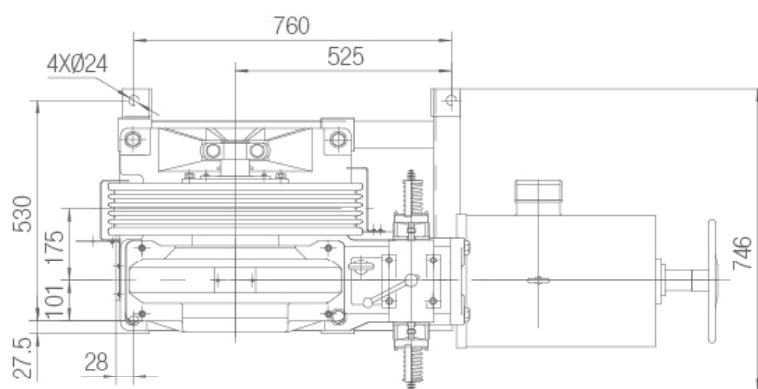
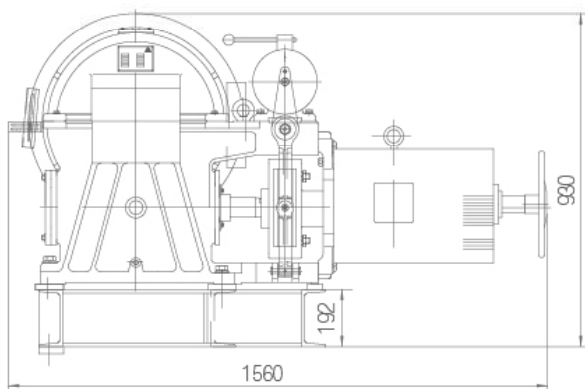

型号 Type	规格 Specification	曳引比 Traction Ratio	额定梯速 Rated Speed (m/s)	额定载重 Rated Load (kg)	静态载重 Static Capacity (kg)	速比 Reduction Ratio	曳引轮规格 Specification of Traction Sheave	槽距 Groove Spacing (mm)	电机型号 Type of Motor	功率 Power (kw)	电机转速 Motor Speed (r/min)	电源 Power Source (V/Hz)	电流 Current (A)	自重 Weight (kg)	推荐提升高度 Recommended lifting height (m)
YJ245	B-VII	2:1	0.5	3000	7000	2:61	Ø620-7-13	18	YPTD180M-6	15	970	380/50	30.3	710	50
	B-IX			YPTD180L1-6					18.5	37.1					