

有齿曳引机

Geard traction machine

YJ360

产品特点 Product Characteristics

曳引比: 1:1、2:1

额定载重: 1000、1150、1600、2300kg

额定梯速: 0.5、1.0m/s

最大提升高度: 60m

噪音级别: <64dB (A)

扭转振动: <3.0mm/s

水平和垂直振动: <0.8mm/s

制动器电压: 制动电压DC110V, 保持电压DC55V

置式: 左置或右置 (此图为右置)

Traction ratio: 1:1、2:1

Rated capacity: 1000、1150、1600、2300kg

Rated elevator speed: 0.5、1.0m/s

Max. lifting height: 60m

Noise level: < 64dB(A)

Torsional vibration: < 3.0mm/s

Horizontal and vertical vibrations: < 0.8mm/s

Brake voltage: DC110V for brake opening, and DC55V for brake holding

Arrangement: left side or right side (The picture is for right side)



外形和安装尺寸 Overall dimensions and mounting dimensions

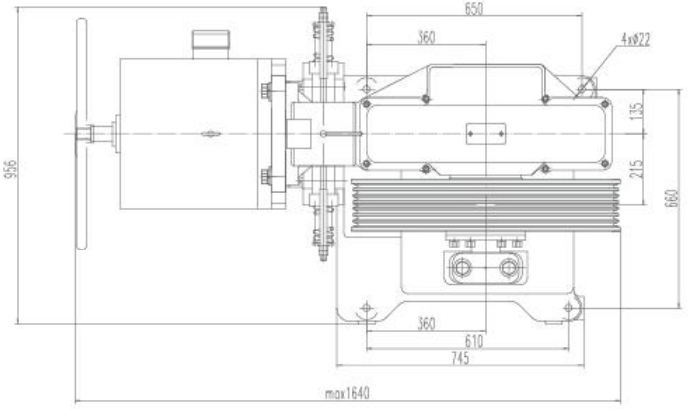
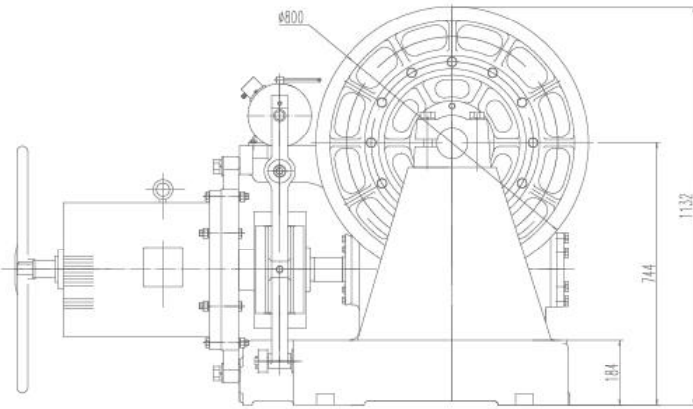

型号 Type	规格 Specification	曳引比 Traction Ratio	额定梯速 Rated Speed (m/s)	额定载重 Rated Load (kg)	静态载重 Static Capacity (kg)	速比 Reduction Ratio	曳引轮规格 Specification of Traction Sheave	槽距 Groove Spacing (mm)	电机型号 Type of Motor	功率 Power (kw)	电机转速 Motor Speed (r/min)	电源 Power Source (V/Hz)	电流 Current (A)	自重 Weight (kg)	推荐提升高度 Recommended lifting height (m)
YJ360	A-I	1:1	0.63	1600	7200	1:61	Ø800-6-13	19	YPTD180M-6	15.0	970	380/50	30.3	1188	30
	A-II	1:1	1.00	1600	7200	1:61	Ø800-6-13	19	YPTD180M1-4	18.5	1470		35.9	1188	50
	B-I	1:1	1.60	1600	7200	2:78	Ø800-7-13	19	YPTD180M2-4	22.0	1470		42	1188	80
	C-I	1:1	2.00	1000	7200	2:61	Ø800-6-13	19	YPTD180M1-4	18.5	1470		35.9	1188	90
	D-I	1:1	2.50	1000	7200	3:73	Ø800-6-13	19	YPTD180M2-4	22.0	1470		42	1188	110
	D-II	1:1	1.75	1600	7200	3:73	Ø800-7-13	19	YPTD180L2-6	22.0	970		43.7	1188	80
	C-II	2:1	0.63	3000	7200	2:61	Ø800-7-13	19	YPTD180L1-6	18.5	970		37.1	1188	35
	D-III	1:1	1.75	2000	7000	3:73	Ø800-7-13	19	YPTD180L4-6	30	970		58.5	1213	80
	C-III	2:1	1.00	5000	12000	2:61	Ø800-7-16	25	YTPD200L2-4	45	1465		84	1293	50