

# 无齿曳引机

Gearless traction machine

## WWTY.8 (2000kg)



### 产品特点 Product Characteristics

曳引比: 2:1	Traction ratio: 2:1
额定载重: 1600、2000Kg	Rated capacity: 1600, 2000Kg
额定梯速: 1、1.6、1.75、2.0m/s	Rated elevator speed: 1、1.6、1.75、2.0m/s
最大轴负荷: 6000kg	Max. shaft load: 6000kg
变频器: 3相, 400V级	Applicable converter: 3 phase 400V
制动器电压: 打开电压DC200V, 保持电压DC100V	Brake voltage: DC200V for brake opening, and DC100V for brake holding
电动机极数: 30极	Number of motor poles: 30 poles

### 产品描述 Product Description

本系列永磁同步无齿曳引机, 采用低速、大力矩的三相永磁同步电动机直接驱动方式, 因此具有低能耗、低噪音、无污染、少维护等优越性。

曳引方式可布置为上拉, 也可布置为下拉, 并具有远距离手动松闸功能; 编码器前置、后置均可。

本系列永磁同步无齿曳引机采用单绕型式, 绕比全部为2:1。

This series of permanent-magnet synchronous gearless traction machines is directly driven by a low-speed, high-torque, 3-phase permanent magnet synchronous motor, and thus has the advantages of low energy consumption, low noises, no pollution, and little maintenance.

These traction machines can be arranged for providing upward traction or downward traction, and have remote manual brake release function; encoder can be preposition and postposition.

This series of permanent-magnet synchronous gearless traction machines adapts single wrap, and roping factor is 2:1.

### 外形和安装尺寸 Overall dimensions and mounting dimensions

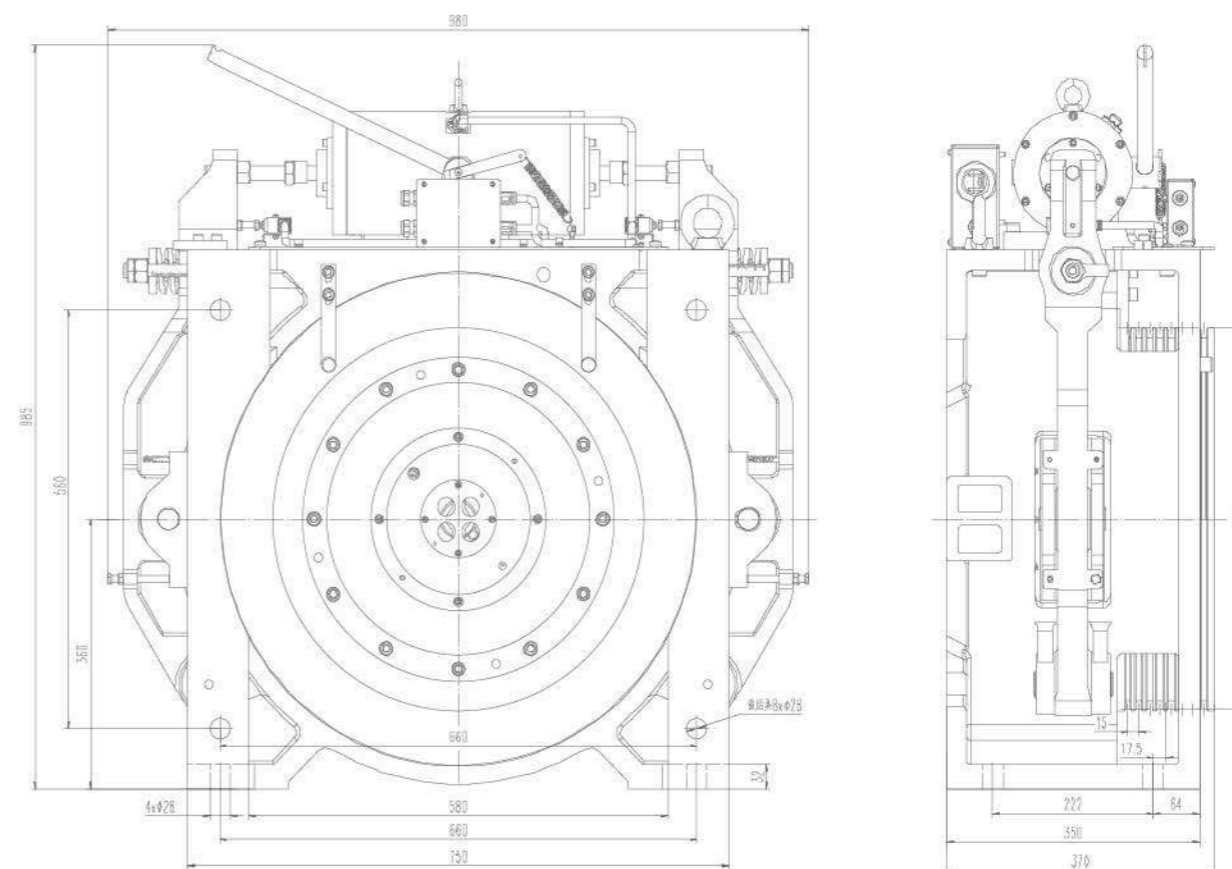

型号 Type	规格 Specification	曳引比 Suspension	梯速 Speed (m/s)	载重 Load (kg)	功率 Power (kW)	转速 Rev (r/min)	频率 Frequency (Hz)	电流 Current (A)	转矩 Torque (N·m)	绳规 Rope	自重 Weight (kg)	推荐提升高度 Recommended lifting height (m)
WWTY	8-10-1600-2	2:1	1	1600	10.9	74.8	18.7	25	1384	7×Φ10	800	45
	8-16-1600-2		1.6		17.3	120	30	40				70
	8-17.5-1600-2		1.75		19	131.2	32.8	43.2				80
	8-20-1600-2		2		21.8	150	37.5	48				90
	8-10-2000-2		1	2000	13.6	74.8	18.7	30	1730	8×Φ10	820	45
	8-16-2000-2		1.6		21.8	120	30	50				70
	8-17.5-2000-2		1.75		23.8	131.2	32.8	54				80
	8-20-2000-2		2		27.2	150	37.5	60				90