

无齿曳引机

Gearless traction machine

WWTY.5C-400

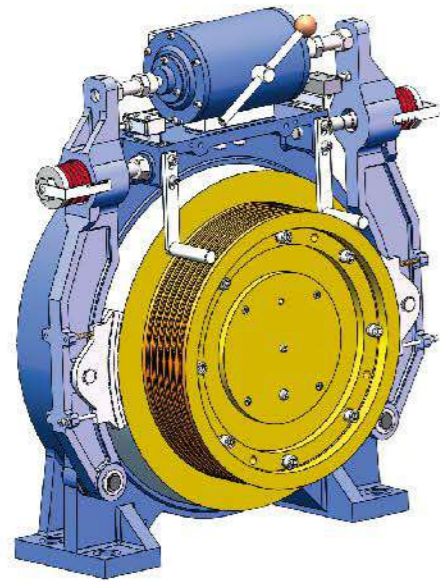

产品特点 Product Characteristics

曳引比: 2:1	Traction ratio: 2:1
额定载重: 800、1000Kg	Rated capacity: 800, 1000Kg
额定梯速: 0.63、1、1.6、1.75m/s	Rated elevator speed: 0.63、1、1.6、1.75m/s
最大轴负荷: 3000kg	Max. shaft load: 3000kg
适配变频器: 3相, 400V级	Applicable converter: 3 phase 400V
制动器电压: 打开电压DC200V, 保持电压DC100V	Brake voltage: DC200V for brake opening, and DC100V for brake holding
电动机极数: 32极	Number of motor poles: 32 poles

产品描述 Product Description

本系列永磁同步无齿曳引机, 采用低速、大力矩的三相永磁同步电动机直接驱动方式, 因此具有低能耗、低噪音、无污染、少维护等优越性。

曳引方式可布置为上拉, 也可布置为下拉, 并具有手动松闸功能; 可选配编码器前置安装方式, 远距离松闸功能。

本系列永磁同步无齿曳引机采用单绕型式, 绕比全部为2:1。

This series of permanent-magnet synchronous gearless traction machines is directly driven by a low-speed, high-torque, 3-phase permanent magnet synchronous motor, and thus has the advantages of low energy consumption, low noises, no pollution, and little maintenance.

These traction machines can be arranged for providing upward traction or downward traction, and have manual brake release function; Can be fitted with the encoder pre installed, remote manual brake release function.

This series of permanent-magnet synchronous gearless traction machines adapts single wrap, and roping factor is 2:1.

外形和安装尺寸 Overall dimensions and mounting dimensions

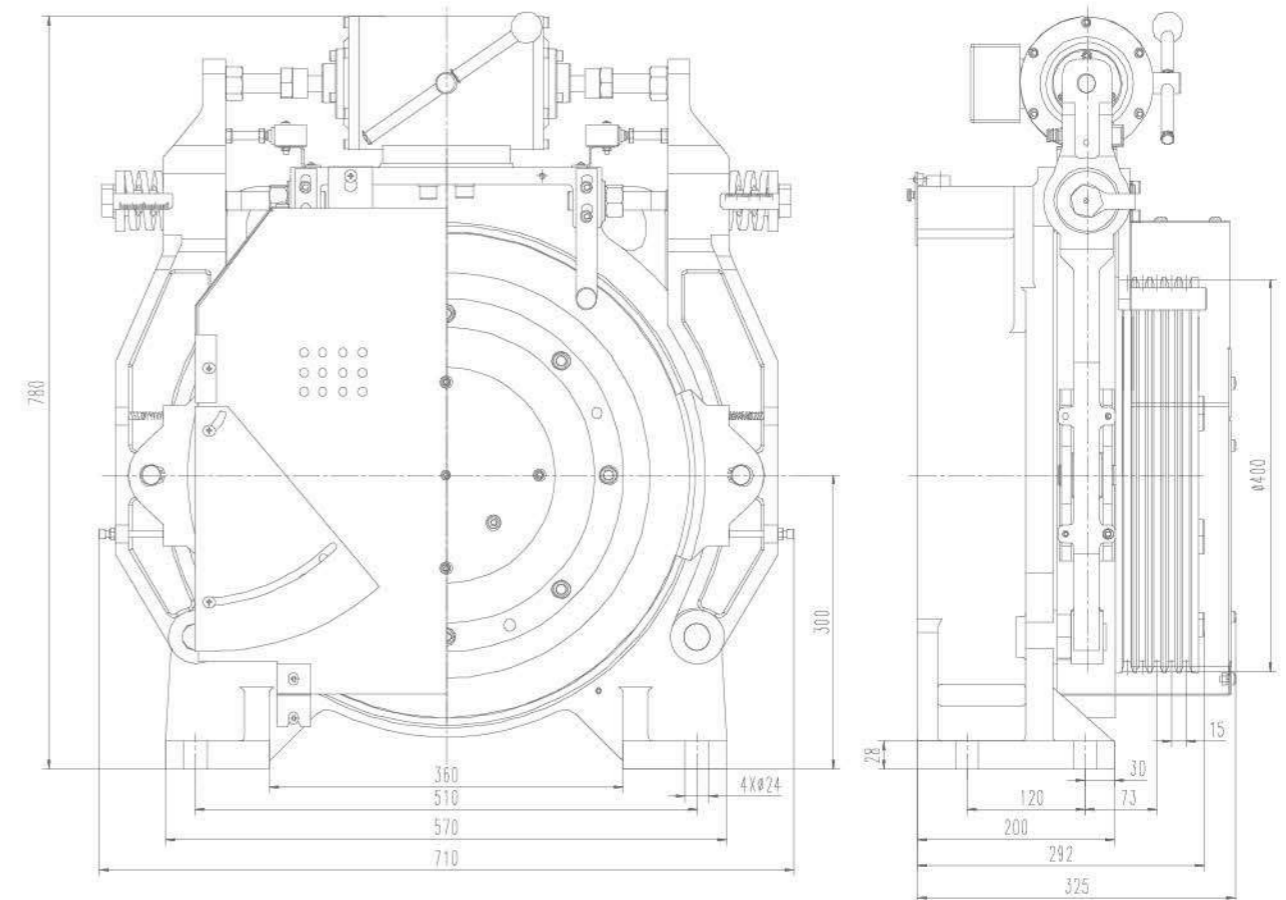

型号 Type	规格 Specification	曳引比 Traction Ratio	梯速 Speed (m/s)	载重 Load (kg)	功率 Power (kW)	转速 Rev (r/min)	频率 Frequency (Hz)	电流 Current (A)	转矩 Torque (N·m)	绳规 Rope	自重 Weight (kg)	推荐提升高度 Recommended lifting height (m)
WWTY	5C-6.3-800	2:1	0.63	800	3.3	60	16	6.8	530	5×Φ10	330	30
	5C-10-800		1		5.3	96	25.6	12				40
	5C-16-800		1.6		8.5	153	40.8	19				70
	5C-17.5-800		1.75		9.3	167	44.5	20.7				80
	5C-6.3-1000	2:1	0.63	1000	4.1	60	16	9	650	5×Φ10	350	30
	5C-10-1000		1		6.5	96	25.6	14.8				40
	5C-16-1000		1.6		10.4	153	40.8	23				70
	5C-17.5-1000		1.75		11.4	167	44.5	26				80