

无齿曳引机

Gearless traction machine

WYJ140H

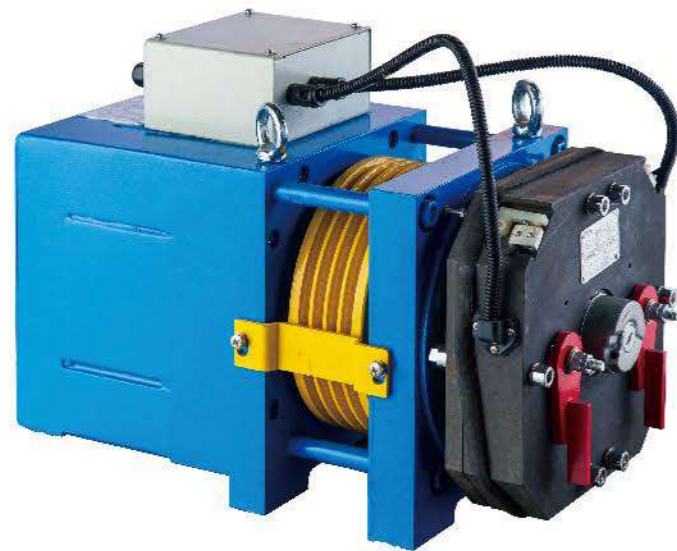

产品特点 Product Characteristics

曳引比: 2:1	Traction ratio: 2:1
最大轴负荷: 1800kg	Max. shaft load: 1800kg
制动器电压: DC110V	Brake voltage: DC110V
曳引轮节径: 210mm	Traction wheel pitch diameter: 210mm
工作制: 60次/小时	Duty type: 60 times/ hour

产品描述 Product Description

本系列无齿曳引机采用细长型设计，结构精致小巧，适用于家用和别墅电梯。
 定子铁心采用独特的叠压设计，无需机座，降低主机重量及成本。
 采用花键配合的轴刹式制动器，结构紧凑，性能优异，并具有远距离手动松闸功能。

This series of toothless traction machine adopts slim design, exquisite structure, suitable for home and villa elevator.
 The stator core adopts a unique laminated design, eliminating the need for a stand and reducing the weight and cost of the host.
 The shaft-brake brake with splined coupling features compact structure, excellent performance and long-distance manual release function.

外形和安装尺寸 Overall dimensions and mounting dimensions

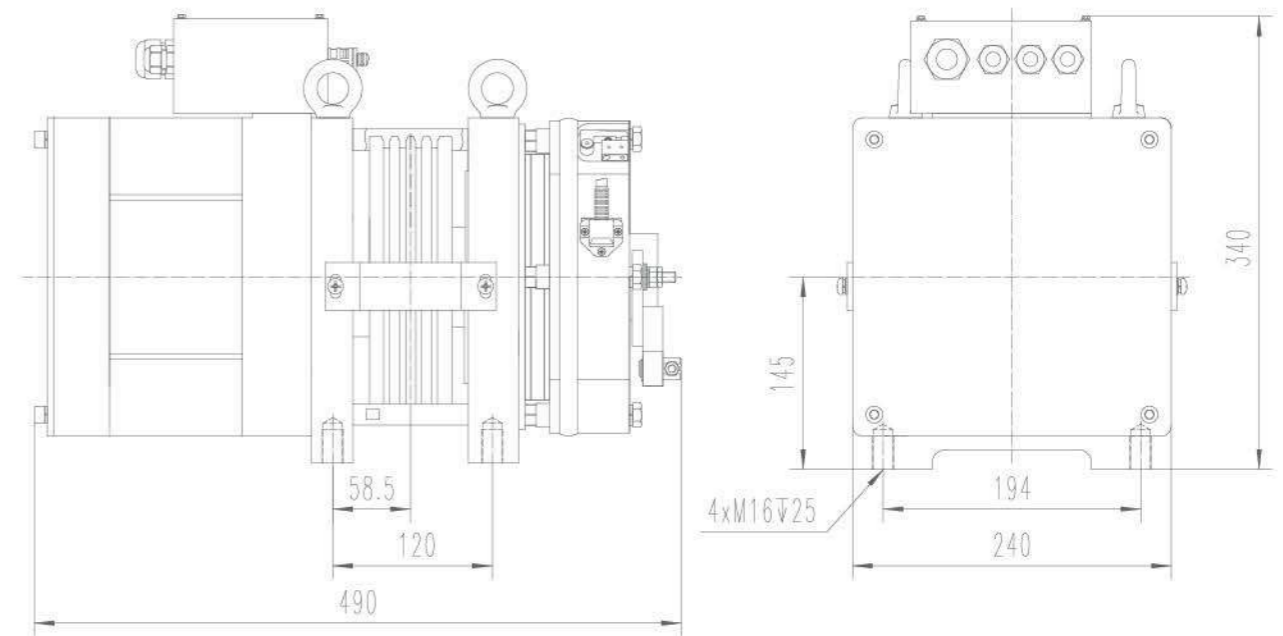

型号 Type	曳引比 Traction Ratio	梯速 Speed (m/s)	载重 Load (kg)	功率 Power (kW)	转速 Rev (r/min)	频率 Frequency (Hz)	电流 Current (A)	转矩 Torque (N·m)	绳规 Rope	电压 Voltage	自重 Weight (kg)	推荐提升高度 Recommended lifting height (m)
WYJ140H-4-400	2:1	0.4	400	1.2	72	6	8.5	158	4xØ8x12	220 或 380	130	20
WYJ140H-10-400		1	400	3	182.4	15.2	8.5	158	4xØ8x12	380	130	20