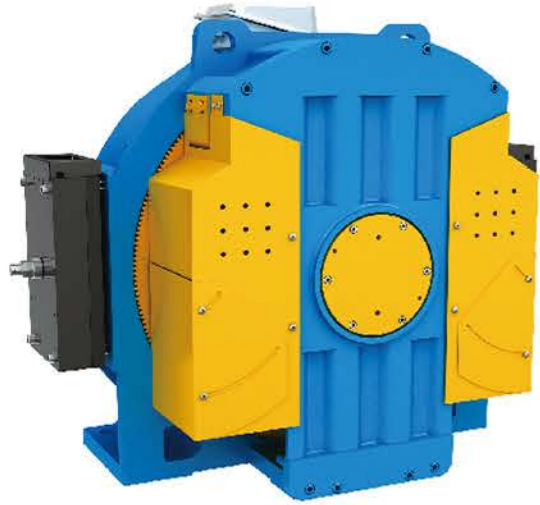

Gearless traction machine

无齿曳引机

MINI9 $\phi 520$ 

产品特点 Product characteristics

曳引比: 1:1、2:1	Traction ratio: 1:1、2:1
额定载重: 1600、3500kg	Rated capacity: 1600、3500kg
额定梯速: 0.5、1.0、1.5、1.75、2.0、2.5、3.0m/s	Rated elevator speed: 0.5、1.0、1.5、1.75、2.0、2.5、3.0m/s
最大轴负荷: 10000kg	Max. shaft load: 10000kg
适配变频器: 3相400V级	Applicable converter: 3 phase 400V
制动器电流: 2×2.6 A	Brake electric current: 2×2.6 A
制动器电压: DC110V	Brake voltage: DC110V
电动机极数: 30级	Number of motor poles: 30 poles
工作制: S5 40%	Duty type: S5 40%

产品描述 Product description

本系列无齿曳引机采用外转子结构，独特的固定中心轴设计，使主机受力更合理。
优异的磁场设计，使主机运行平稳，噪音小，温升高。

This series of gearless machine adopts an outer rotor structure and a unique fixed center axis design, making the stress of the host machine more reasonable.
The excellent magnetic field design allows the host to run smoothly with low noise and low temperature rise.

外形和安装尺寸 Overall dimensions and mounting dimensions

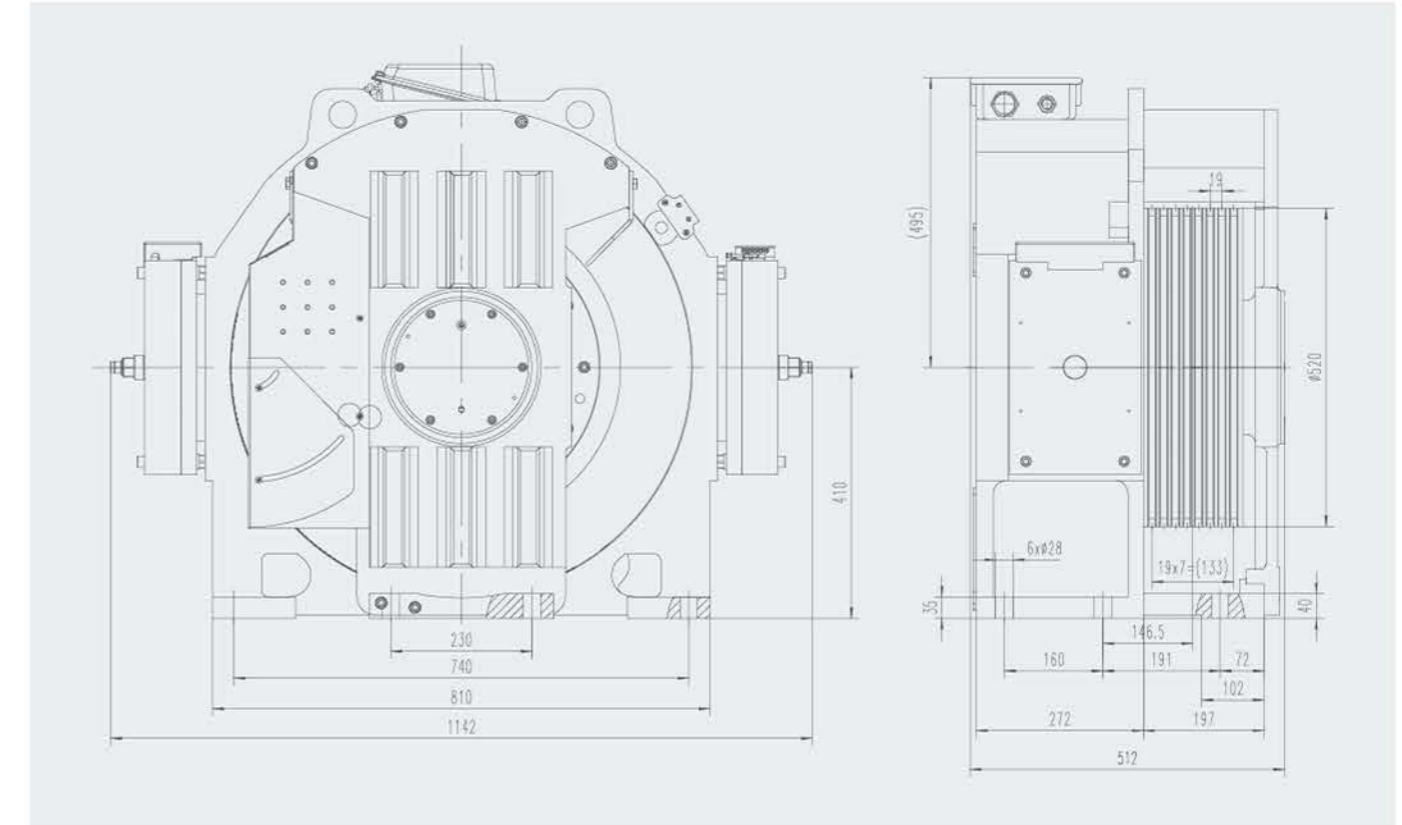

型号 Type	规格 Specification	曳引比 Traction ratio	梯速 Speed (m/s)	载重 Load (kg)	功率 Power (kW)	转速 Rev (r/min)	频率 Frequency (Hz)	电流 Current (A)	转矩 Torque (N·m)	绳规 Rope	自重 Weight (kg)	推荐提升高度 Recommended lifting height (m)
Mini	9-10-1600-1	1:1	1.0	1600	10.4	36.8	9.2	27.5	2700	8× $\phi 13$	1030	45
	9-15-1600-1		1.5		15.6	55.2	13.8	40				70
	9-17.5-1600-1		1.75		18.2	64.4	16.1	43.4				80
	9-20-1600-1		2.0		20.8	73.6	18.4	51.5				80
	9-25-1600-1		2.5		26.0	92	23	61				120
	9-30-1600-1		3.0		31.2	110	27.5	72				120
Mini	9-5-3500-2	2:1	0.5	3500	11.4	36.8	9.2	31	2955	8× $\phi 13$	1030	20
	9-10-3500-2		1.0		22.8	73.6	18.4	54				45
	9-15-3500-2		1.5		34	110	27.5	79				60
	9-17.5-3500-2		1.75		39.7	128.4	32.1	93				70
	9-20-3500-2		2.0		45.4	146.8	36.7	103				80